

JUNQUAN[®]
JUNQUAN AUTOMATION
—— 君权自动化 ——

产品说明书

Product Specifications

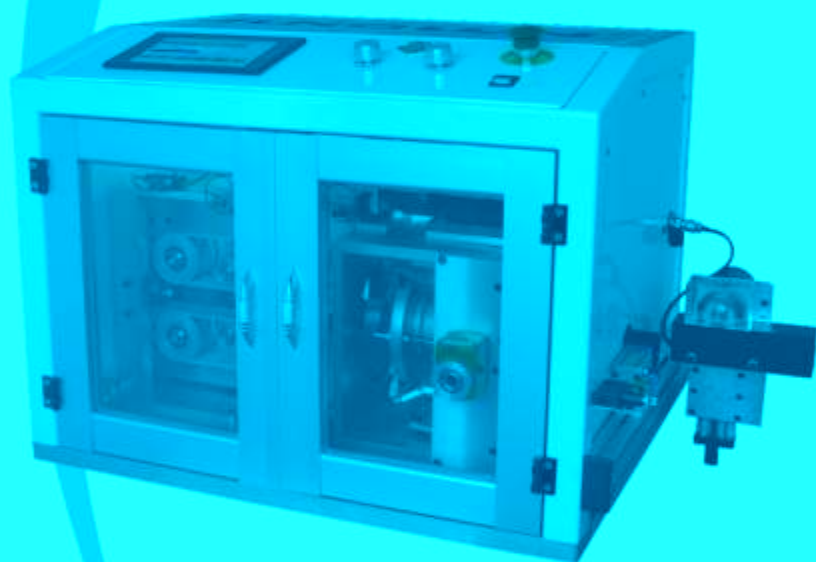

ZD660G-6600 自动喷油机

浙江君权自动化设备有限公司
ZHEJIANG JUNQUAN AUTOMATION CO.,LTD

1	1
2	2
3	3
4	4
5	5
6	7
7	10
8	13

1

2

3

4

ZDQG

5

6

1

2

3

4

7

8

10

1

2

3

11

1

220 10%

50-60

2

3

4

5

6

7

100Kg

8

9

0573-82331888 0573-82339199

	20mm-99999mm
	0 1mm
	7- 32
	0.01mm
/	1.5m
	0.5mm
	0.7mm
	1.5mm
	100
	65bB
	(SKH-51)
	220V
	800w
	80Kg
	(W)580 (L)556 (H)780mm

1 (1-1)

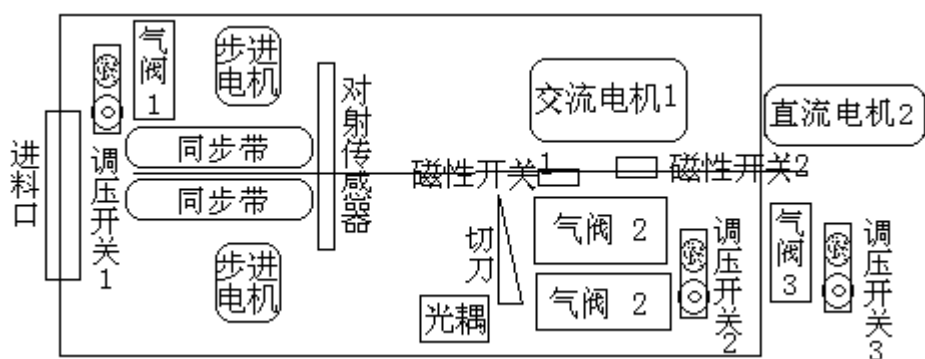

1-1

2 1-2

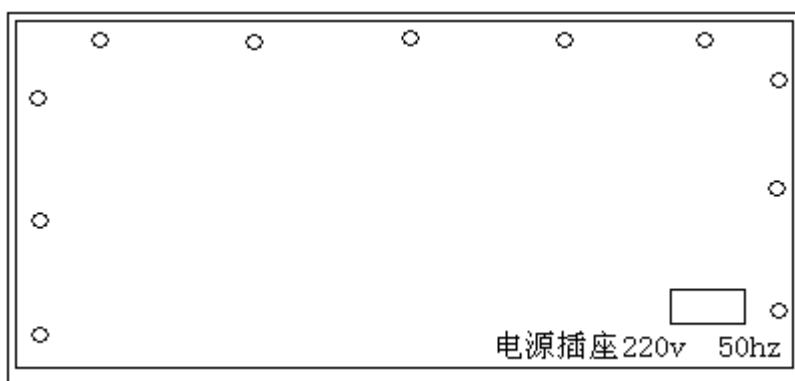

1-2

(1) AC220V 50-60HZ

2

3 1-3



1-3

4 1-4



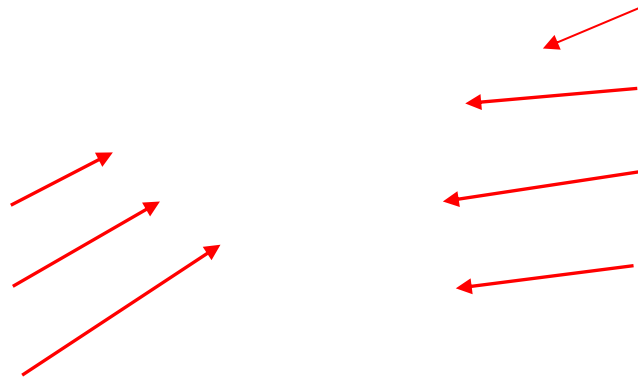

1-4

5

1-5

5

1-5

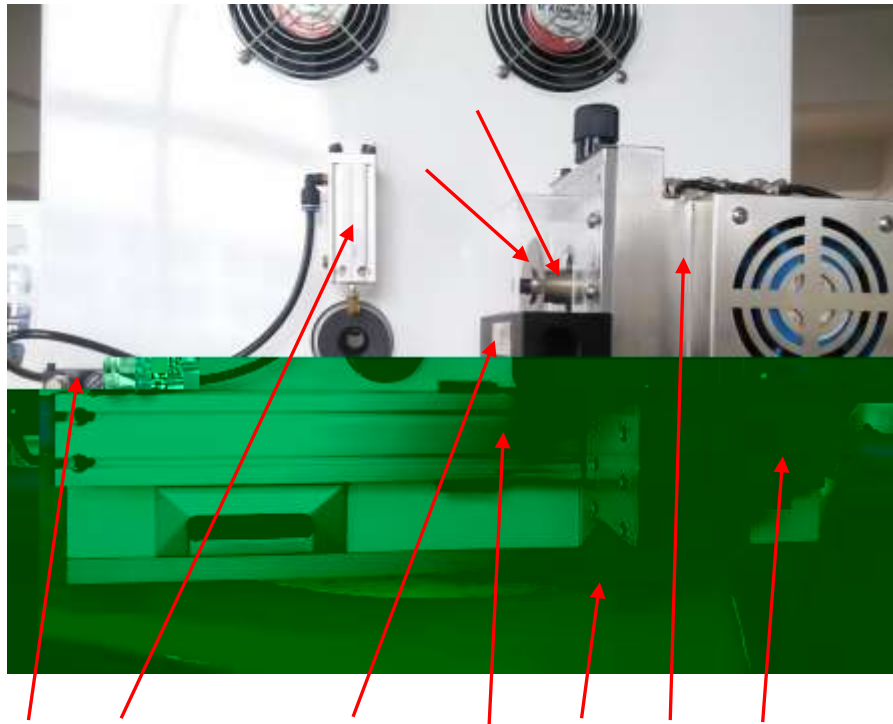

1-5

3

1

2-1



2-1

English

2.

2-2

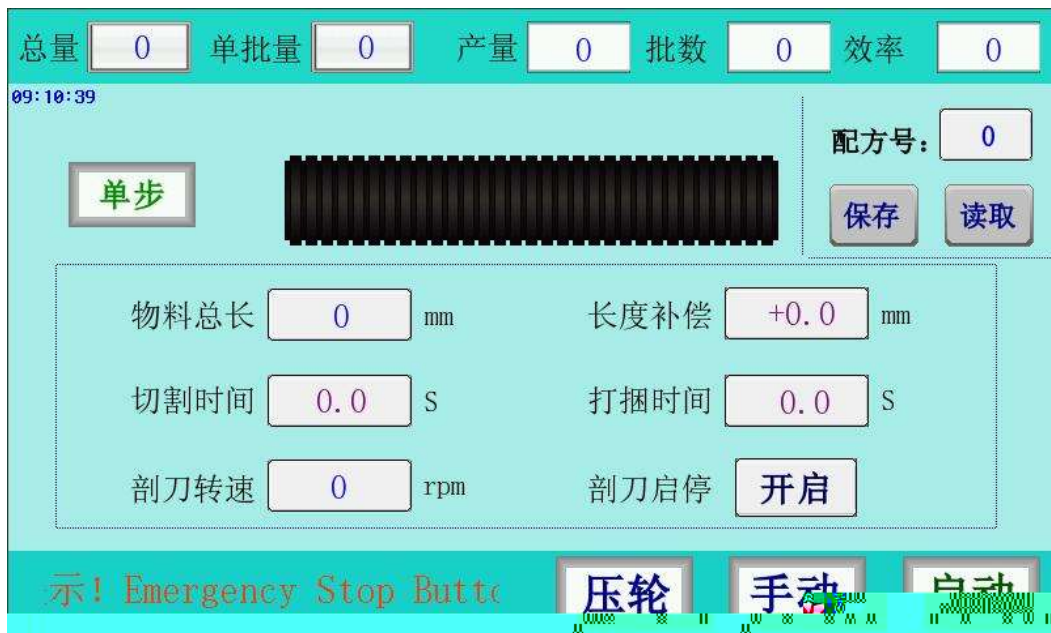

2-2

0-99 /

20-99999mm

0.1-9.9s

/

/

/

*

3.

2-3



2-3

4.

2-4



62900000

X.XX

-10 20

/

/

1

3-1



3-1

(1mm)

2

3-2

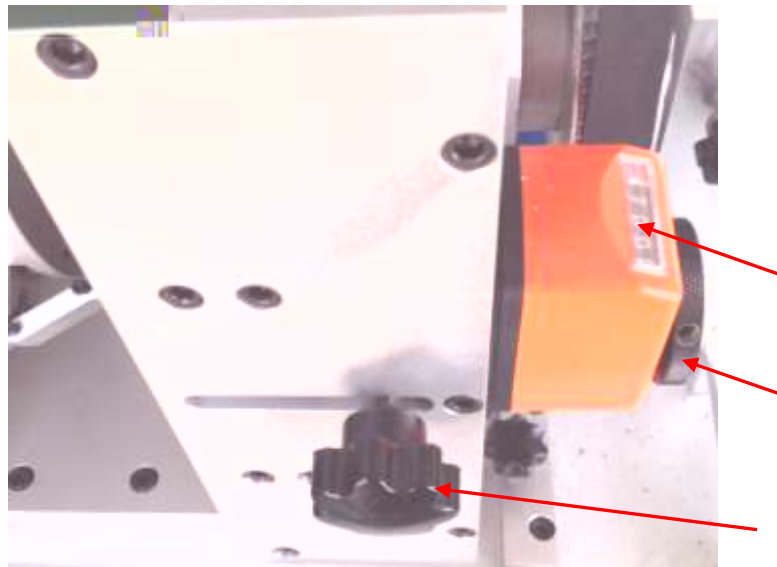

3-2

3

3-3

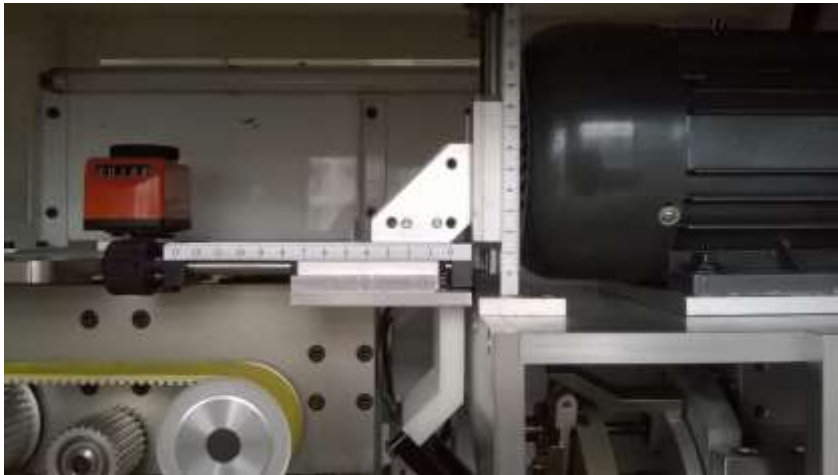

3-3

4

3-4

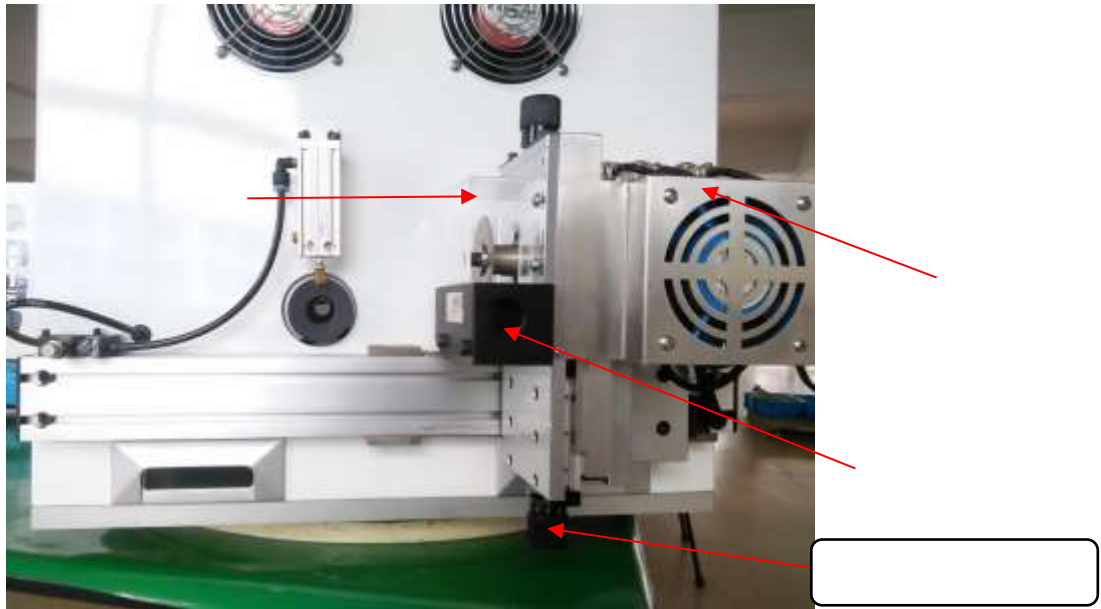

3-4

5

3-5

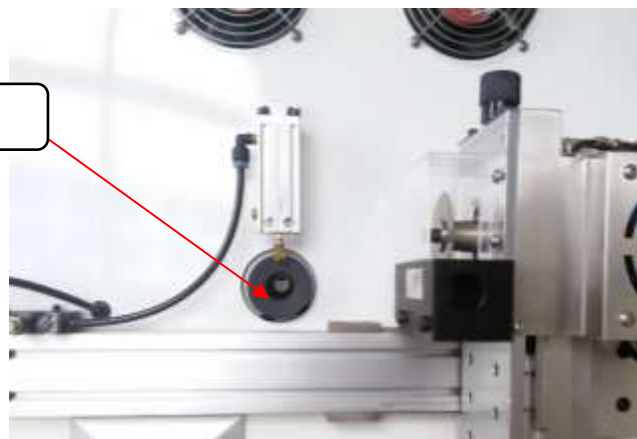
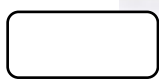

3-5

6

3-6

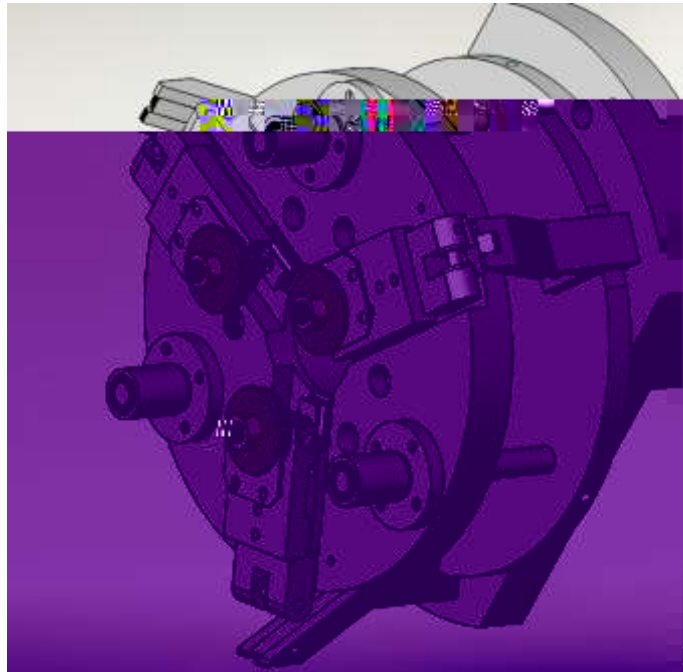

3-6

7

3-7

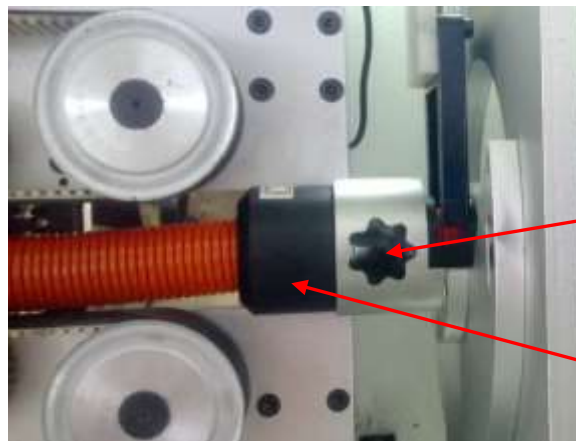

3-7

8

3-8



3-8

0.4pa

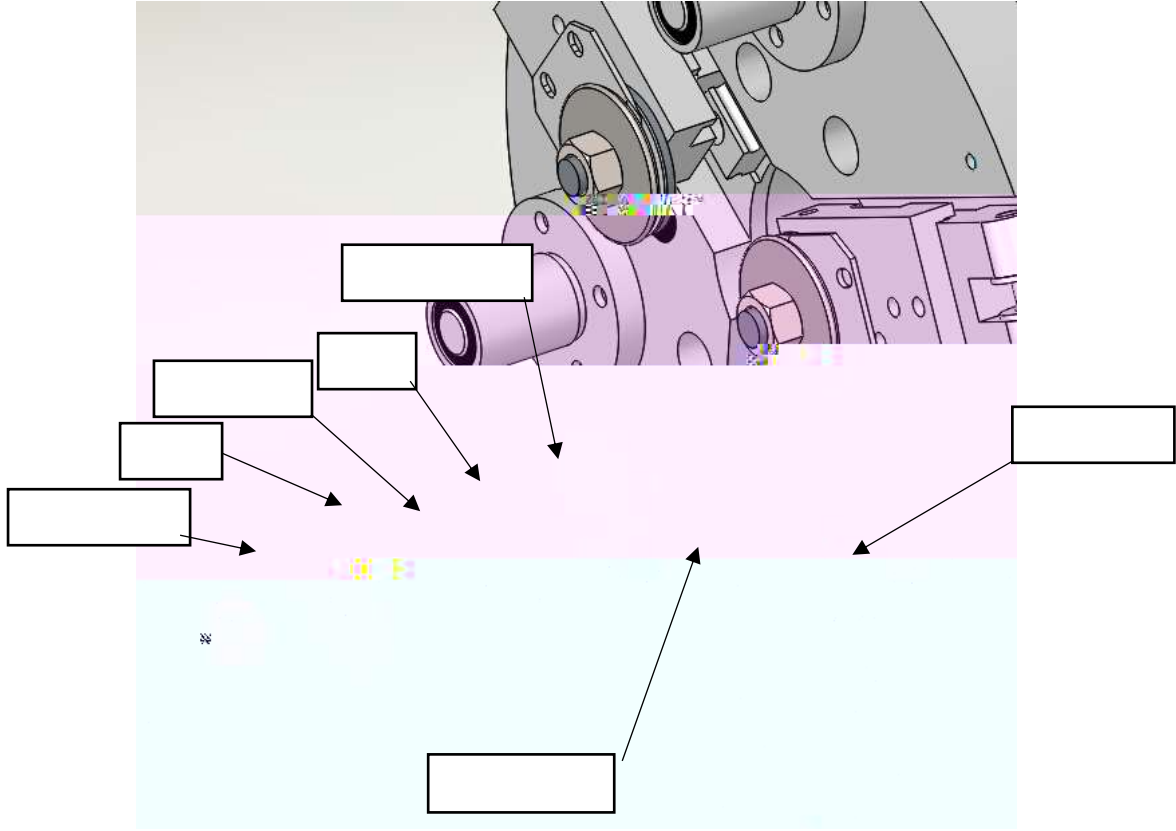

3-9

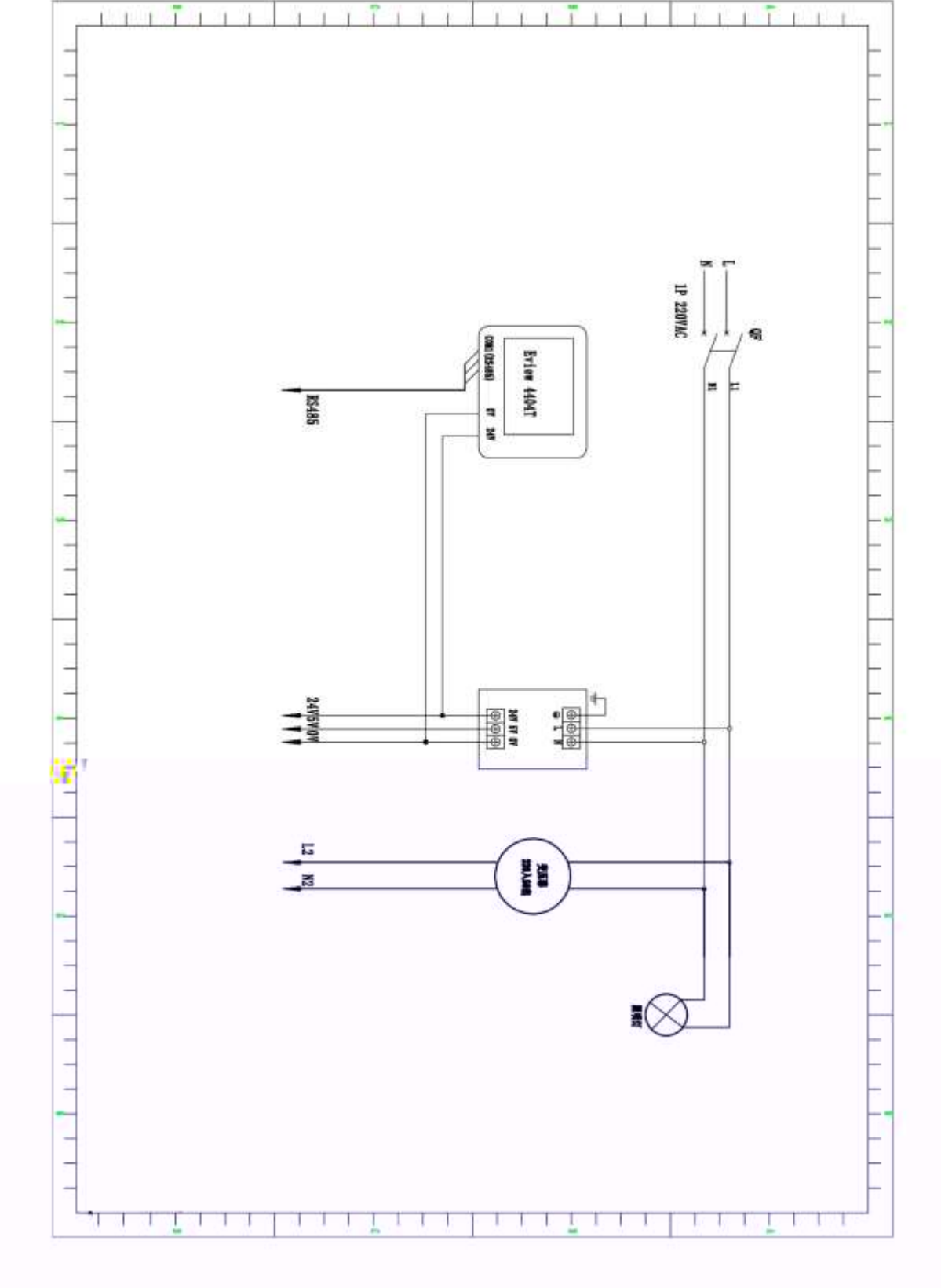

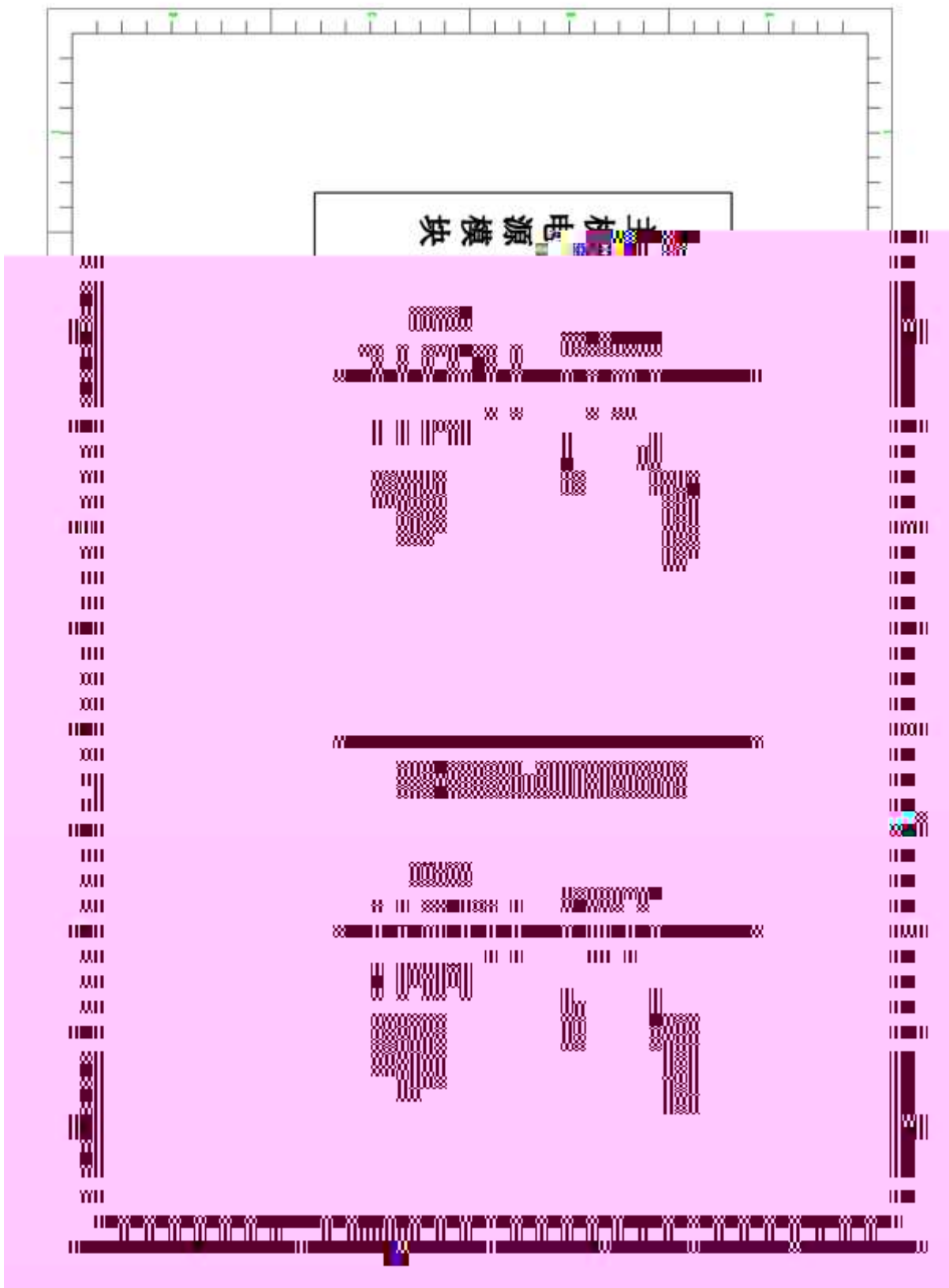

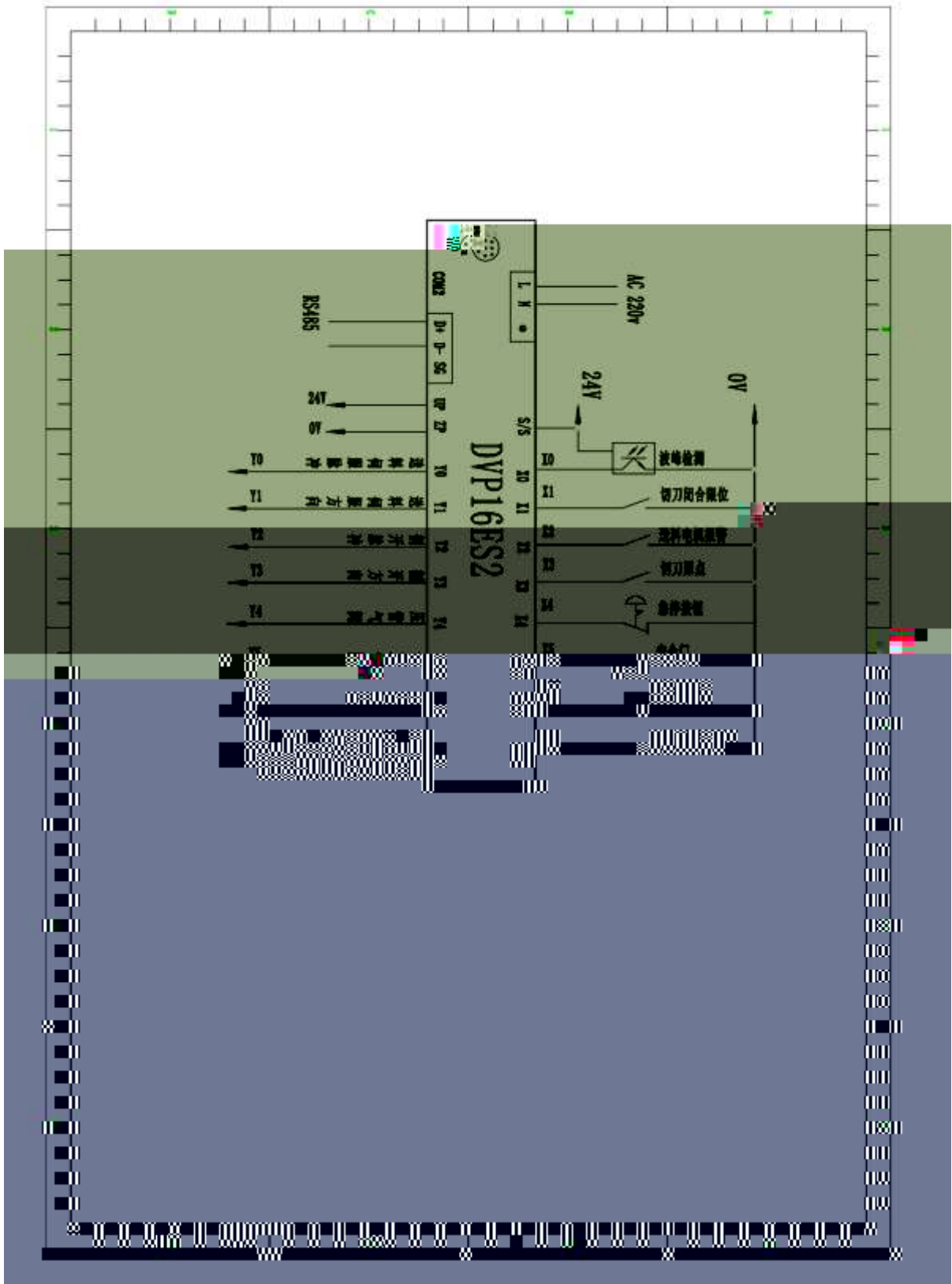

主机

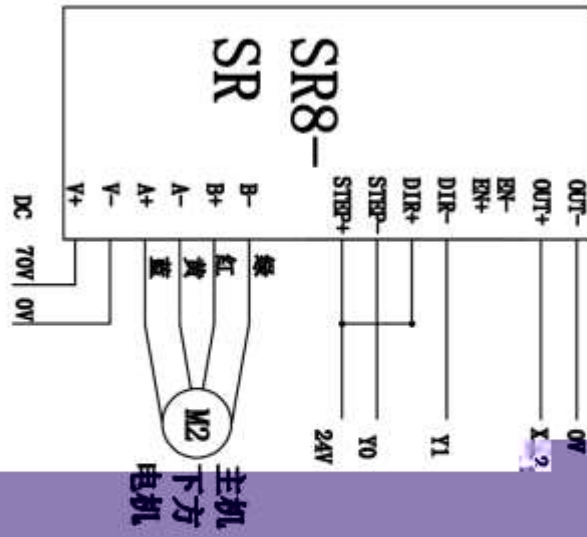
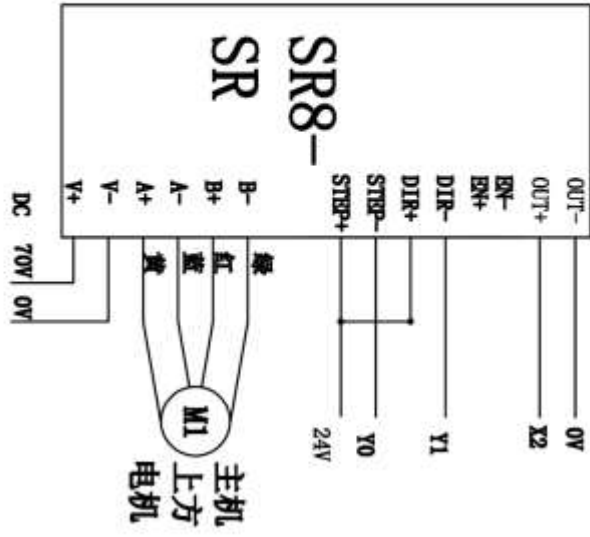

*注意电机线的颜色

0573-82331888 82330999

www.junquan.com

/Tel 0086-577-62900000 62901111 82199999

/Fax 0086-577-62902918 62902199

E-mail:junquan@wz.zj.cn

586

/Tel 0086-573-82331888 82330999

/Fax 0086-573-82301199